

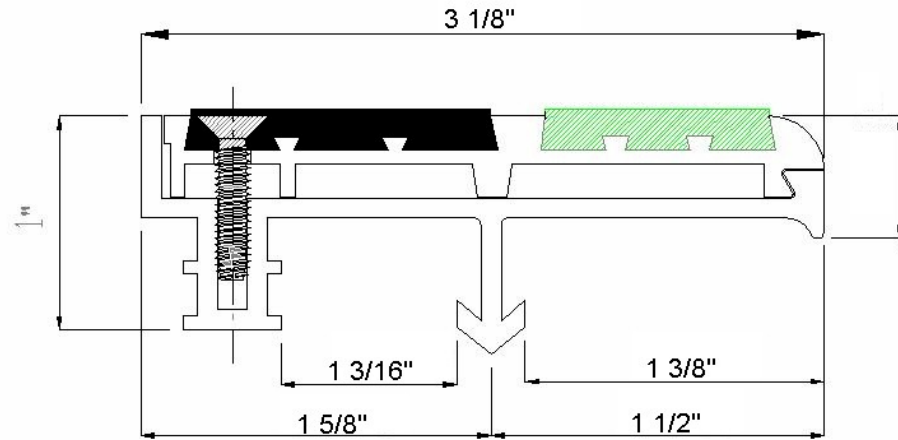

**Wooster  
Products Inc.**



| Job Name:             | Page: ___ of ___ |        |      |       |
|-----------------------|------------------|--------|------|-------|
| Customer:             | Notes:           | Length | Qty. | Color |
| PO#:                  |                  |        |      |       |
| Architect's Name:     |                  |        |      |       |
|                       |                  |        |      |       |
| <b>Approved By:</b>   |                  |        |      |       |
| <b>Approval Date:</b> |                  |        |      |       |
|                       |                  |        |      |       |
| Representative:       |                  |        |      |       |
| Fax No:               |                  |        |      |       |